



Buy it for looks. Buy it for life.®

Specifications

DESCRIPTION



- Plastic & metal construction with a chrome finish
- G1/2 inlet connections
- Includes 3F handheld shower(spray, spray & massage, massage) & slide bar and soap dish

OPERATION



- Easy installation
- Handheld shower height is adjustable

STANDARD



- Designed to meet GB standards

WARRANTY



- 1 years limited warranty against leaks and drips

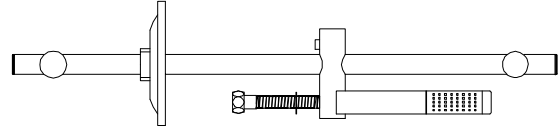

Handheld Shower & Slide Bar
And Soap Dish Trim Kit
Models: A805-30

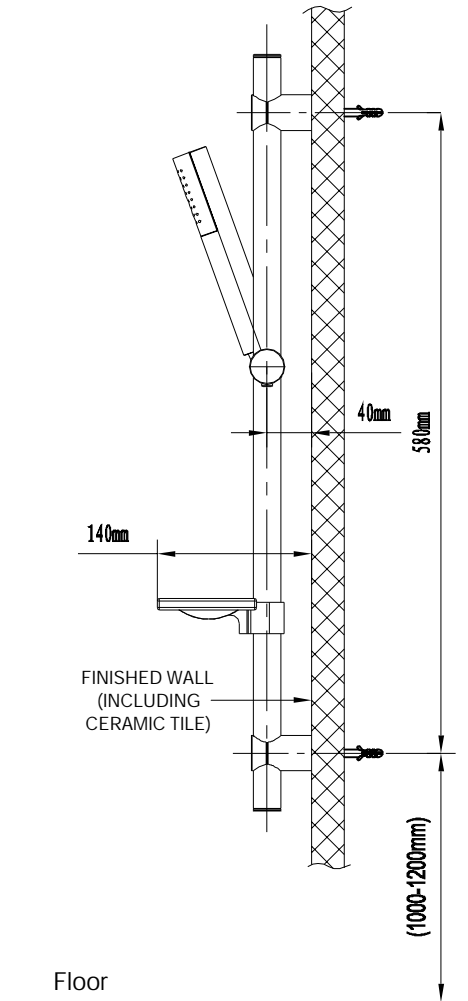
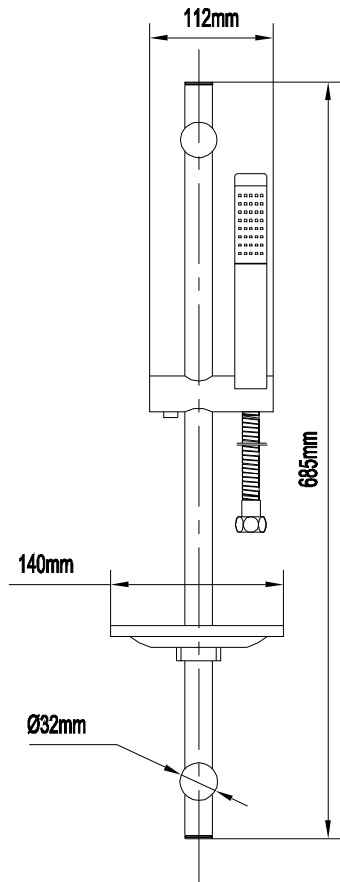

CRITICAL DIMENSION

(DO NOT SCALE)